

AMS 4712

Miniaturized pressure transmitter with 4 .. 20 mA output



FEATURES

- **Calibrated and temperature compensated pressure sensor with two-wire 4 .. 20 mA current loop output**
- **Differential / gage, bidirectional differential, absolute and barometric versions**
- **Wide variety of pressure ranges: 5 mbar up to 2 bar**
- **Piezoresistive sensing element**
- **High precision digital signal conditioning**
- **High accuracy at room temperature**
- **Low overall error within a temperature range of -25 .. +85°C**
- **Supply voltage range: 8 .. 36 V**
- **Current limitation**
- **Protected against reverse polarity**
- **Compact and robust package**
- **Dust- and water-tight (IP67)**
- **M5 circular sensor connector**
- **Ready to use, simple and quick installation**
- **RoHS and REACH compliant**

GENERAL DESCRIPTION

AMS 4712 is a series of miniaturized pressure transmitters suitable for industrial applications and high precision measurements. All AMS 4712 can be powered within a supply voltage range of $V_S = 8 \dots 36 \text{ V}$ and provide an industrial two-wire 4 .. 20 mA current loop output. They are calibrated and temperature compensated in a wide temperature range of $-25 \dots +85^\circ\text{C}$.

AMS 4712 comes in a robust plastic package and is ready to use. Pressure is applied either via two barbed side ports for differential (relative) or bidirectional differential pressure transmitter types or via a single port for absolute or barometric types. The two-wire current loop output is established using an M5 circular sensor connector. AMS 4712's package is dust- and water-tight conforming to IP67.

The pressure transmitters in the AMS 4712 series are available for various applications and pressure ranges: Differential (relative) devices in pressure ranges from 0 .. 5 mbar up to 0 .. 2 bar, absolute pressure variants for 0 .. 1 bar and 0 .. 2 bar as well as a barometric type for 0.7 .. 1.2 bar. Bidirectional differential devices are available from $-5 \dots +5 \text{ mbar}$ up to $-1 \dots +1 \text{ bar}$ for measurement of positive and negative pressure differences. Other pressure ranges are available on request.

TYPICAL APPLICATIONS

- Static pressure sensing
- Dynamic pressure sensing
- Barometric pressure sensing
- Vacuum measurement
- Level measurement
- Gas flow measurement
- Heating, Ventilation and Air Conditioning (HVAC)

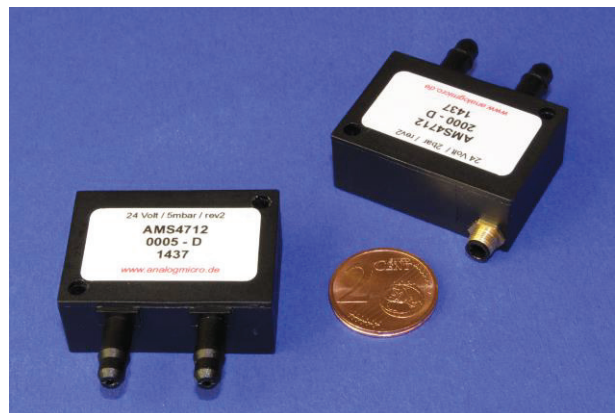

analog microelectronics

Analog Microelectronics GmbH
An der Fahrt 13, D – 55124 Mainz

Phone: +49 (0)6131/91 0730-0
Fax: +49 (0)6131/91 073-30
Internet: www.analogmicro.de
E-Mail: info@analogmicro.de

March 2015 - Rev. 4.0

AMS 4712

Miniaturized pressure transmitter with 4 .. 20 mA output

PRESSURE RANGES

Pressure transmitter type (code)	Pressure type	Pressure range in mbar	Burst pressure ¹⁾ in bar	Pressure range in PSI	Burst pressure ¹⁾ in PSI
Ultra low pressure					
AMS 4712-0005-D	differential / relative	0 .. +5	>0.35	0 .. 0.073	>5
AMS 4712-0010-D	differential / relative	0 .. 10	>0.35	0 .. 0.145	>5
AMS 4712-0005-D-B	bidirectional differential	-5 .. +5	>0.35	-0.073 .. +0.073	>5
AMS 4712-0010-D-B	bidirectional differential	-10 .. +10	>0.35	-0.145 .. +0.145	>5
Low pressure					
AMS 4712-0020-D	differential / relative	0 .. 20	>0.5	0 .. 0.290	>7
AMS 4712-0050-D	differential / relative	0 .. 50	>1	0 .. 0.725	>15
AMS 4712-0100-D	differential / relative	0 .. 100	>1	0 .. 1.450	>15
AMS 4712-0020-D-B	bidirectional differential	-20 .. +20	>0.5	-0.290 .. +0.290	>7
AMS 4712-0050-D-B	bidirectional differential	-50 .. +50	>1	-0.725 .. +0.725	>15
AMS 4712-0100-D-B	bidirectional differential	-100 .. +100	>1	-1.450 .. +1.450	>15
Standard pressure					
AMS 4712-0200-D	differential / relative	0 .. 200	>5	0 .. 2.901	>72
AMS 4712-0350-D	differential / relative	0 .. 350	>5	0 .. 5.076	>72
AMS 4712-0500-D	differential / relative	0 .. 500	>5	0 .. 7.251	>72
AMS 4712-1000-D	differential / relative	0 .. 1000	>5	0 .. 14.50	>72
AMS 4712-2000-D	differential / relative	0 .. 2000	>5	0 .. 29.01	>72
AMS 4712-0200-D-B	bidirectional differential	-200 .. +200	>5	-2.901 .. +2.901	>72
AMS 4712-0350-D-B	bidirectional differential	-350 .. +350	>5	-5.076 .. +5.076	>72
AMS 4712-1000-D-B	bidirectional differential	-1000 .. +1000	>5	-14.50 .. +14.50	>72
AMS 4712-1000-A	absolute	0 .. 1000	>5	0 .. 14.50	>72
AMS 4712-2000-A	absolute	0 .. 2000	>5	0 .. 29.01	>72
AMS 4712-1200-B	barometric	700 .. 1200	>5	10.15 .. 17.40	>72

Table 1: AMS 4712 standard pressure ranges (other ranges on request)

Notes:

- 1) Burst pressure is defined as the maximum pressure, which can be applied to one pressure port relative to the other port (or while only one pressure port is connected) without causing damages / leaks.

MAXIMUM RATINGS

Parameter	Minimum	Typical	Maximum	Units
Absolute maximum supply voltage: V_{max}			40	V
Operating and storage temperature: T	-25		85	°C
Common mode pressure: p_{CM} ¹⁾			5	bar

Table 2: Maximum ratings

Notes:

- 1) Common mode pressure is defined as the maximum pressure, which can be applied simultaneously on both pressure ports of a differential or bidirectional transmitter without causing damages, while no differential pressure is applied.

AMS 4712

Miniaturized pressure transmitter with 4 .. 20 mA output

SPECIFICATIONS

All parameters apply to $V_S = 24\text{ V}$, $T_{op} = 25^\circ\text{C}$ and $R_L = 100\ \Omega$, unless otherwise stated.

Parameter	Minimum	Typical	Maximum	Units
Current loop output signal				
@ specified minimum pressure (see "pressure ranges") ¹⁾		4		mA
@ specified maximum pressure (see "pressure ranges") ¹⁾		20		mA
Full span output (FSO) ²⁾		16		mA
without pressure (only bidirectional differential types)		12		mA
Accuracy³⁾ @ $T_{op} = 25^\circ\text{C}$				
Ultra low pressure types (5, 10 mbar)		± 1.0	± 1.5	%FSO
Low pressure types (20, 50, 100 mbar)		± 0.5	± 1.0	%FSO
Standard pressure types (≥ 200 mbar)		± 0.3	± 0.5	%FSO
Overall error⁴⁾ @ $T_{op} = -25 \dots 85^\circ\text{C}$				
Ultra low pressure types (5, 10 mbar)		± 1.5	± 2.5	%FSO
Low pressure types (20, 50, 100 mbar)		± 1.0	± 2.0	%FSO
Standard pressure types (≥ 200 mbar)		± 0.5	± 1.0	%FSO
Long term stability			< 0.5	%FSO/a
Nonlinearity ⁵⁾	-0.3	< 0.1	0.3	%FSO
Resolution analog output signal			0.05	%FSO
Supply voltage (V_S to Ground)	$V_{S,min}$ ⁶⁾	24	36	V
Transmitter power consumption ($I_{OUT} = 20\text{ mA}$, $R_L = 0\ \Omega$)			0.48	W
Current limitation $I_{OUT,max}$			22.5	mA
Protection against reverse polarity			40	V
Response time (10% .. 90% rise time)		2,5	4	ms
Load resistor R_L			600	Ω
Dependency of I_{OUT} on V_S ⁷⁾			< 0.1	%FSO
Pressure Changes	10^6			
Compensated operating temperature range	-25		85	$^\circ\text{C}$
Weight without cable		20		gram
Media compatibility		See notes ^{8), 9)}		
Protection classification ¹⁰⁾		IP67		

Table 3: Specifications

SPECIFICATION NOTES:

- 1) Pressure ranges are specified in *Table 1*.
- 2) The Full Span Output (FSO) is the algebraic difference between the current loop output at the specified minimum pressure and the current loop output at the specified maximum pressure (nominal FSO = 16 mA).
- 3) The accuracy is defined as the maximum deviation of the measurement value from the ideal transfer function at room temperature (RT) in %FSO including the adjustment error (offset and span), nonlinearity, pressure hysteresis and repeatability. Nonlinearity is the measured deviation from the best fit straight line (BFSL) across the entire pressure range. Pressure hysteresis is the maximum deviation of the output value at any pressure within the specified range when the pressure is cycled to and from the specified minimum or maximum pressure. Repeatability is the maximum variation of the output value at any pressure within the specified range over 10 pressure cycles.

AMS 4712

Miniaturized pressure transmitter with 4 .. 20 mA output

- 4) The overall error is defined as the maximum deviation of the measurement value from the ideal transfer function in %FSO across the entire temperature range (-25 .. 85°C).
- 5) Defined as best fit straight line (BFSL).
- 6) The minimum supply voltage $V_{S,min}$ depends on the used load R_L and is given by $V_{S,min} = 8 V + 20 mA \cdot R_L$.
- 7) The given value is the maximum deviation from the output voltage at $V_S = 24 V$ over the complete supply voltage range at any pressure in the specified range. It is normalized to the FSO.
- 8) Media compatibility of pressure port 1 (for a description of port 1, see *Figure 3*): fluids and gases non-corrosive to ceramics, silicon, Pyrex, RTV silicone rubber and Zytel PA66.
- 9) Media compatibility of pressure port 2 (for a description of port 2, see *Figure 3*): clean, dry gases, non-corrosive to ceramics, silicon, RTV silicone rubber, gold, tin and Zytel PA66 (alkaline or acidic liquids can destroy AMS 4712)
- 10) With tubes connected at port 1 and port 2 for differential and bidirectional differential pressure transmitters and with a tube connected at port 2 for absolute and barometric pressure transmitters.

FUNCTIONAL DESCRIPTION

AMS 4712 uses a piezoresistive silicon chip as sensing element and a mixed-signal integrated circuit (ASIC) for signal conditioning, which are assembled on a ceramic substrate and housed in a robust plastic package.

The physical pressure applied to the transmitter's pressure ports is measured at AMS 4712's piezoresistive pressure sensing element, where the pressure is converted into a differential voltage signal, which is almost proportional to the pressure. Using the signal conditioning ASIC this differential voltage signal is converted into a standardized analog two-wire current loop output of $I_{OUT} = 4 .. 20 mA$.

The signal conditioning is done in the following way (see *Figure 1*):

At first the sensing element's differential voltage signal is pre-amplified and converted into a digital signal using a 14-bit A/D converter (ADC). This digitized signal is processed mathematically by the ASIC's integrated microcontroller unit. To achieve a calibrated and temperature compensated output signal the microcontroller unit uses individual correction coefficients and a mathematical correction algorithm, which are stored in the ASIC's EEPROM during AMS 4712's factory calibration process. The temperature value needed for the temperature compensation is measured directly at the piezoresistive sensing element, too. An 11-bit D/A converter (DAC) converts the corrected digital signal into a voltage signal, which is converted into a two-wire current loop output by the voltage-to-current converter.

The standardized two-wire current loop output $I_{OUT} = 4 .. 20 mA$ (or $12 \pm 8 mA$ for bidirectional differential types) is a linear function of the applied pressure.¹ It is independent of the applied supply voltage.

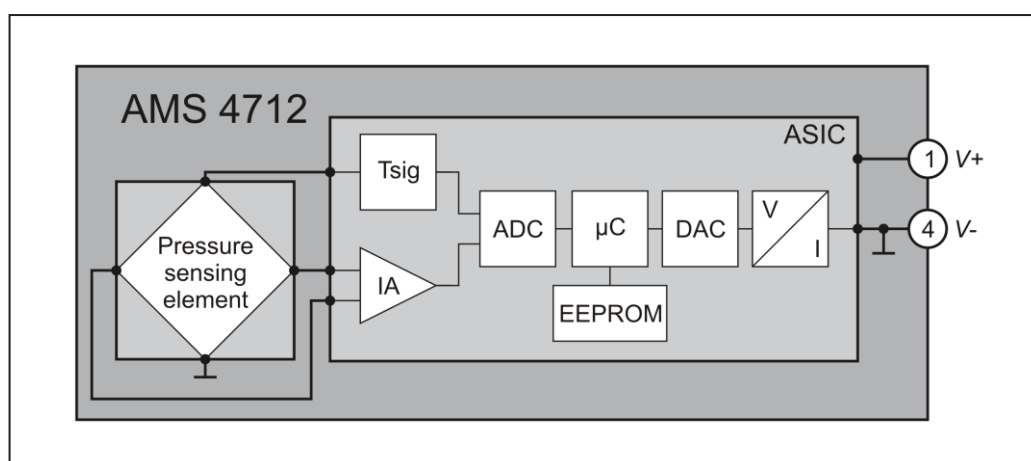

Figure 1: AMS 4712's block diagram

¹ The applied pressure is the pressure difference between port 1 and port 2 for differential and bidirectional differential pressure transmitters. For relative pressure types it is the pressure difference between port 1 and ambient pressure and for absolute and barometric pressure types it is the pressure at port 2 (for the definition of ports see *Figure 3*).

AMS 4712

Miniaturized pressure transmitter with 4 .. 20 mA output

INITIAL OPERATION

AMS 4712's package provides a dust- and water-tight protection and a maintenance-free lifetime. The package can be screw mounted in a fast and easy way using the two through bores (\varnothing 3.2 mm) at the package's edges.

The electrical connection is established using the integrated M5 circular sensor connector (for pinout see *Figure 3*) and a suitable cable with female M5 sensor connector (see "additional equipment"). As shown in *Figure 2* pin 1 (V+) is directly connected to the power supply's positive output and pin 4 (V-) is connected to Ground via a load resistor R_L , which can be installed far away from the pressure transmitter. I_{OUT} can be measured using the voltage drop V_A over R_L with $I_{OUT} = V_A / R_L$ ².

The required minimum supply voltage $V_{S,min}$ depends on the used load R_L and is given by the following equation:

$$V_{S,min} = 8 \text{ V} + 20 \text{ mA} \cdot R_L$$

Please take care that the power supply can provide at least 20 mA.

The pressure connection is made using the package's pressure ports (barbed hose connectors). Depending on the type of pressure transmitter and the type of measuring pressure one or two of the pressure ports are connected to the measuring media/volume. For the pressures at port 1 and port 2 (for definition of the ports see *Figure 3*) the following requirements have to be fulfilled, where p_1 is the pressure at port 1 and p_2 is the pressure at port 2:

for differential pressure (type AMS 4712-XXXX-D):

$$p_1 > p_2$$

for relative / gage pressure (type AMS 4712-XXXX-D):

$$p_1 > p_{ambient}, p_1 = \text{measuring pressure}$$

for bidirectional differential pressure (type AMS 4712-XXXX-D-B):

$$p_1 > p_2 \text{ or } p_1 < p_2 \text{ possible}$$

for absolute pressure (type AMS 4712-XXXX-A):

$$p_2 = \text{measuring pressure}$$

for barometric pressure (type AMS 4712-XXXX-B):

$$p_2 = \text{measuring pressure}$$

The maximum pressures (see *Table 1*) and the guidelines concerning media compatibility (specification notes 8) and 9)) have to be taken into account.

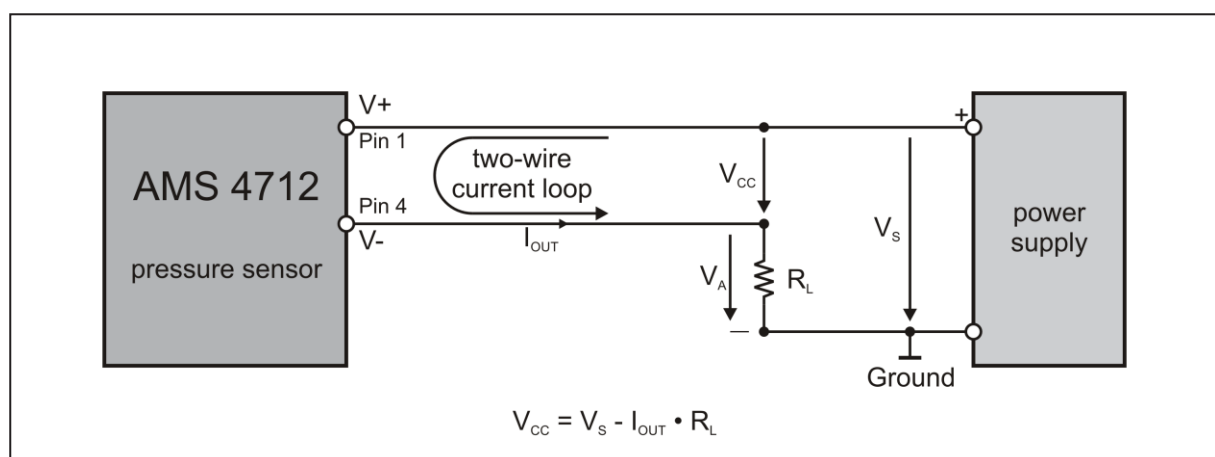

Figure 2: Electrical connection of AMS 4712

² If very long cables are used to connect AMS 4712 with R_L the voltage drop over the cable resistance should be taken into account for the determination of V_S .

AMS 4712

Miniaturized pressure transmitter with 4 .. 20 mA output

DIMENSIONS AND PINOUT

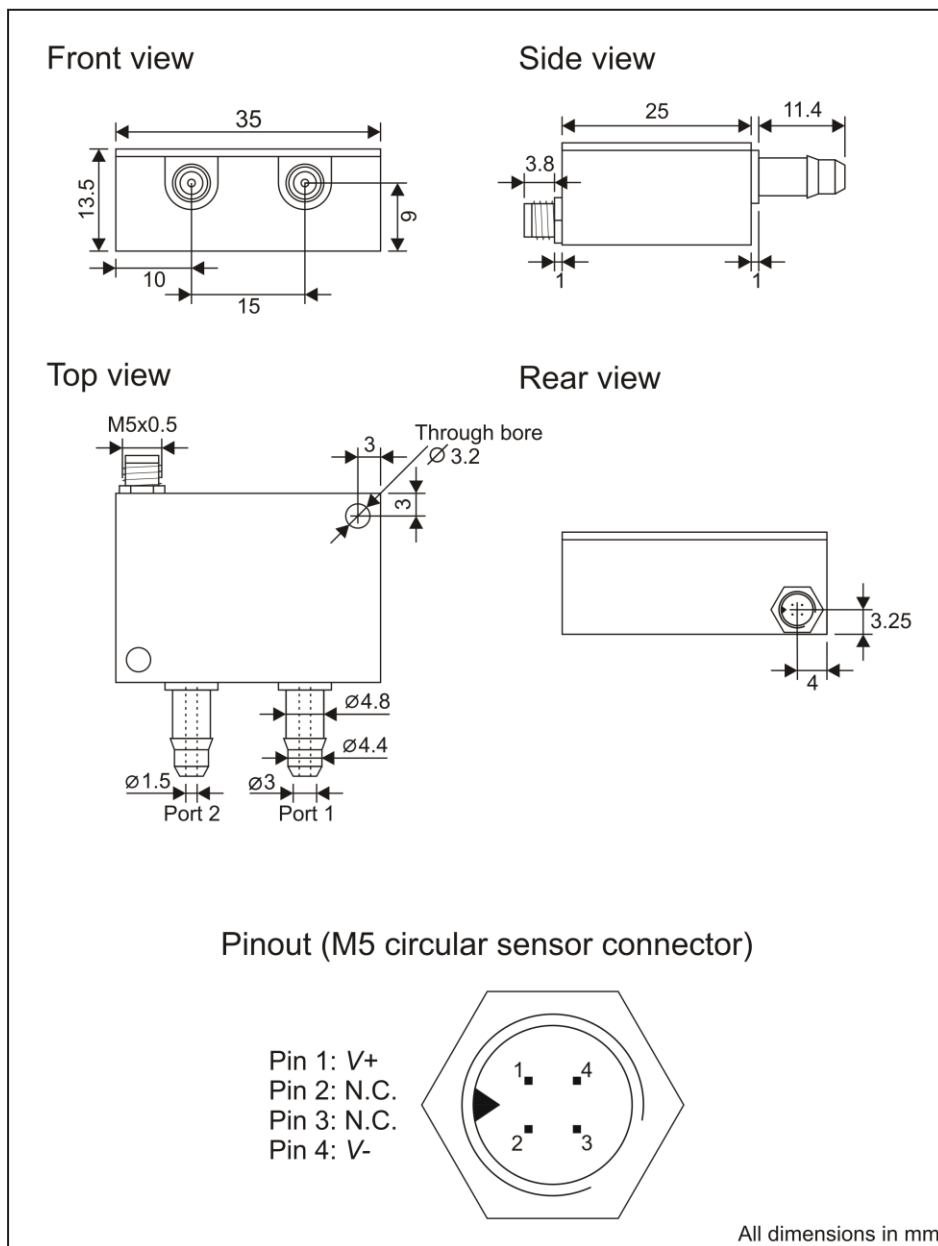

Figure 3: Dimensions and pinout of AMS 4712's package

Notes:

1. For absolute and barometric pressure transmitters only pressure port 2 is available.
2. Package material is Zytel PA66.
3. The electrical connection is established using an M5 sensor connector series 707 from Binder GmbH.
4. For pressure connections Analog Microelectronics recommends a silicone tubing (inner diameter $\varnothing_{ID} = 3.2 \text{ mm}$, outer diameter $\varnothing_{OD} = 6.4 \text{ mm}$) or soft PU tubing ($\varnothing_{ID} = 4 \text{ mm}$, $\varnothing_{OD} = 6 \text{ mm}$).
5. If silicone tubing is used it is recommended to use hose clamps to reduce the risk of leaks at high pressure.

AMS 4712

Miniaturized pressure transmitter with 4 .. 20 mA output

INFORMATION FOR ORDERING

Ordering code:

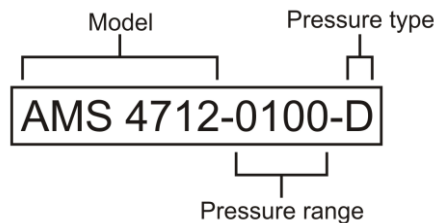

Pressure range:

Pressure range code	mbar	PSI	kPa
0005	5	0.073	0.5
0010	10	0.145	1
0020	20	0.290	2
0050	50	0.725	5
0100	100	1.450	10
0200	200	2.901	20
0350	350	5.076	35
0500	500	7.251	50
1000	1000	14.50	100
1200	1200	17.40	120
2000	2000	29.01	200

Table 4: Pressure ranges

Pressure type:

Pressure type code	Available pressure ranges
D differential / relative (gage)	0 .. 5 mbar to 0 .. 2000 mbar
D-B bidirectional differential	-5 .. +5 mbar to -1000 .. +1000 mbar
A absolute	0 .. 1000 mbar and 0 .. 2000 mbar
B barometric (absolute)	700 .. 1200 mbar

Table 5: Pressure types

ADDITIONAL EQUIPMENT

ORDER NUMBER	DELIVERY FORM
AMS4712-CABLE	3-wire cable with mating M5 sensor connector (2 m long) wiring: brown – V+, blue – NC, black – V-
AMS4712-PU-TUBING	matching soft PU-Tubing (please order in meters)

your distributor
www.amsys.de



AMS 4712

Miniaturized pressure transmitter with 4 .. 20 mA output

NOTES



Analog Microelectronics GmbH reserves the right to amend any dimensions, technical data or other information contained herein without prior notification.