



# AMS 5812 - Ratiometry in pressure sensors

OEM pressure sensor AMS 5812 [1] is a sensor which generates both an analog and a digital output signal proportional to the pressure. According to the datasheet the analog signal is ratiometric yet the digital signal is not. Why?

Taking the AMS 5812 by way of example, in the following AMSYS shall describe what is to be understood by the term “ratiometry” in pressure sensing technology and what is meant by “ratiometric error”.

- [Description of the AMS 5812](#)
- [How the AMS 5812 works](#)
- [Ratiometric analog output signal](#)
- [Ratiometric error](#)
- [Non-ratiometric pressure sensors](#)
- [Summary](#)

## Description of the AMS 5812

The AMS 5812 series consists of OEM pressure sensors which enable absolute, relative, differential and bidirectional differential pressure (positive and negative pressure) to be measured. The sensors are individually calibrated to the specified setpoints during manufacture. Deviations from the ideal transfer characteristic caused by changes in temperature are individually corrected. The range of adjustment is from -25°C to 85°C. Minimum error and good long-term stability are the result of the use of high-quality piezoresistive pressure sensing elements, modern integrated signal conditioning and optimized algorithms.

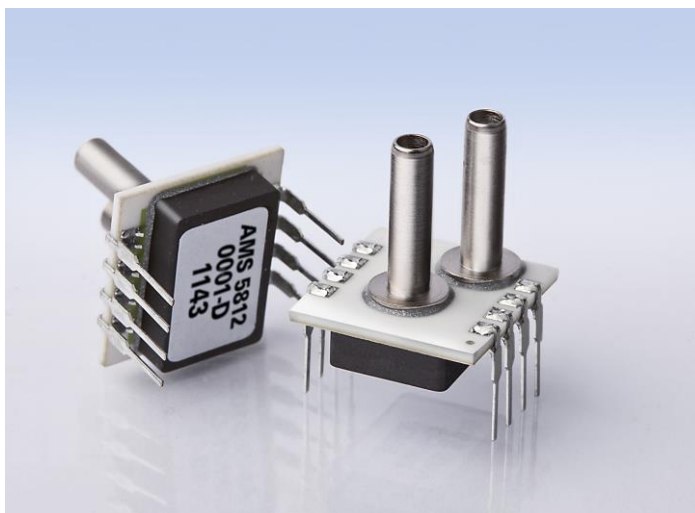

**Figure 1:** OEM pressure sensor AMS 5812 with an analog and digital output

The AMS 5812 has two independent outputs at a supply voltage of 5 V: an analog ratiometric voltage output at 0.5–4.5 V (or 2.5 V  $\pm$  2 V for the bidirectional differential version [2]) and a digital output for I<sup>2</sup>C transmission [3].

The different variants are available for pressure ranges of 0–0.075 psi to 100 psi and can also be calibrated to customer specifications.

The ceramic substrate with dual inline soldering connections and a ceramic housing lend the pressure sensor high mechanical stability.



# AMS 5812 - Ratiometry in pressure sensors

## How the AMS 5812 works

Pressure is measured on the AMS 5812 by a modern, piezoresistive silicon pressure sensing element. Here, the pressure applied to the MEMS or microelectromechanical system sensing element is converted into an analog signal which is almost proportional to the applied pressure. This voltage signal is then amplified by the CMOS ASIC (see Figure 2) and converted into a digital value in the downstream ADC. On the AMS 5812 the resolution of the ADC is 16 bits.

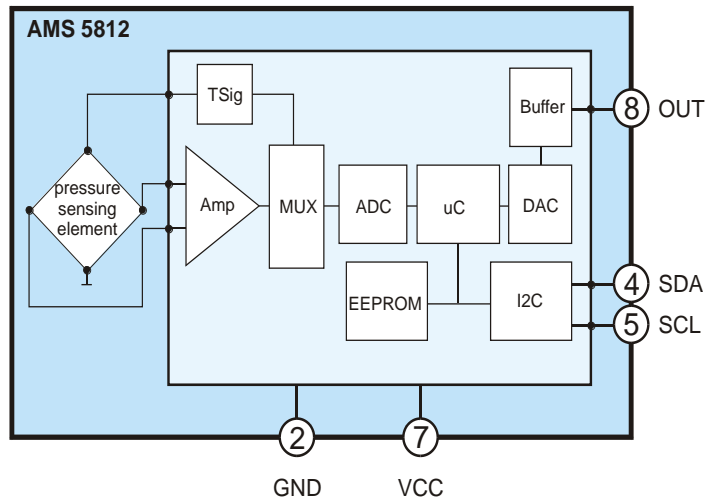

Figure 2: circuit diagram of the AMS 5812 OEM pressure sensor

In order to obtain standardized output values, the digitized signals are electronically calibrated in the microprocessor block, temperature compensated and linearized. During calibration and prior to delivery correction coefficients are determined at various pressures and temperatures for each individual sensor regarding the ideal transfer characteristic and stored in the EEPROM. The temperature is measured directly on the sensing element in contact with the measurement medium, thus yielding a value which is practically undistorted.

The program in the integrated microprocessor cyclically compensates for the digital pressure signal based on the respective pressure and temperature values with the help of the correction coefficients. The calibrated values are written to the ASIC output register and continuously updated, typically every 0.5 ms. Both the pressure and temperature are available as digital data, with the pressure also converted into an analog voltage signal by a downstream (11-bit) DAC.

## Ratiometric analog pressure sensing element signal

In the first approximation the following equation applies to the output voltage of piezoresistive sensing elements, such as those used in the sensors in the AMS 5812 series:

$$V_{Mz} = S \cdot P \cdot V_{CC} , \quad (1)$$

where  $S$  = the sensitivity of the sensing element,  $P$  = pressure and  $V_{CC}$  = the supply voltage.

It is evident that the output signal of the piezoresistive silicon sensing element  $V_{Mz}$  is directly proportional to supply voltage  $V_{CC}$  and applied pressure  $P$ , i.e.  $V_{Mz} = f(P, V_{CC})$ . This means that the sensor element signal changes in sync with changes in the supply voltage, among other things, an effect described as “ratiometricity”.



# AMS 5812 - Ratiometry in pressure sensors

If, for example, supply voltage  $V_{CC}$  changes by  $\pm 5\%$  to  $V_{CC,1}$ , output signal  $V_{Mz}$  of the pressure sensing element changes in the same ratio. The following ratiometric condition applies:

$$\frac{V_{CC,1}}{V_{CC}} = \frac{V_{Mz,1}}{V_{Mz}} \quad (2)$$

## Non-ratiometric digital output signal

Most modern-day sensors use a microprocessor switched after the analog amplifier for signal conditioning. An analog-to-digital converter (ADC) is thus needed between the sensing element and the processor.

The ADC generally has three inputs for analog voltages. These are as follows:

- The pressure-dependent output voltage  $V_{Mz}(P)$  of the sensing element to be measured
- Upper reference voltage  $V_{Ref+}$
- Lower reference voltage  $V_{Ref-}$ .

The input value of the ADC to be converted is equivalent to sensing element output voltage  $V_{Mz}$ . The upper reference voltage is either the processor's operating voltage  $V_{CC}$  or an applied external reference voltage. This limits the maximal measurable input voltage. For reasons of cost it is of course prudent to use operational voltage  $V_{CC}$ . Lower reference voltage  $V_{Ref-}$  is either the processor's ground ( $V_{ground}$ ) or an alternative external reference voltage. For the ADC this represents the offset.

The ADC digitizes the analog output signal from the sensing element in relation to its reference voltage  $V_{Ref+}$ . At the same analog input value and identical resolution but with a smaller reference voltage the digital value at the ADC output increases and vice versa.

If we initially only consider the sensor element and AD converter, the digitized value downstream of the ADC depends on the pressure, resolution and ratio of the sensor element signal to the reference voltage.

$$DC_{out} = V_{Mz}(P)/V_{Ref+} \quad (3)$$

If supply voltage  $V_S$  of the sensor element and reference voltage  $V_{Ref}$  of the ADC change synchronously (e.g.  $V_{Ref+} = V_{CC}$ ), the ratio of the sensing element output voltage  $V_{Mz}$  to the reference voltage remains constant at the same pressure and the digital output signal is independent of the change in supply voltage  $V_{CC}$  (combination of equations (1) and (3)).

This means that the signal is not ratiometric. It does not change in relation to the change in supply voltage but is only proportional to pressure  $P$ .

# AMS 5812 - Ratiometry in pressure sensors

## Ratiometric analog output signal

If we now look at the further path of the AMS 5812 signal, the digitized signal must be changed into an analog signal by a DA converter (DAC; *Figure 3*). The DAC converts the digital signal into an analog signal in relation to its reference voltage. At the same digital input value and identical resolution the analog output drops at a smaller DAC reference voltage  $V_{Ref+,DAC}$ . Under the same conditions the signal becomes larger when the reference voltage increases.

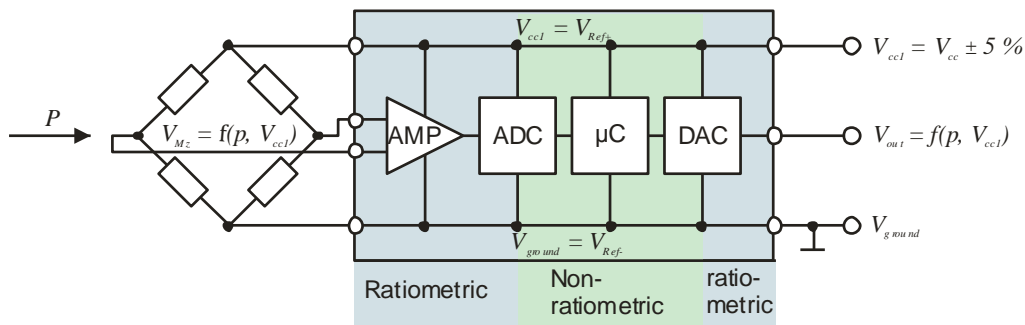

**Figure 3:** schematic circuit diagram of a ratiometric pressure sensor

The reference voltages of the ADC and DAC,  $V_{Ref+,ADC}$  and  $V_{Ref+,DAC}$ , are both connected to supply voltage  $V_{CC}$  on the AMS 5812. This means that a change in  $V_{CC}$  causes a synchronous change in the sensing element output signal on the one hand and in the digital signal, converted back into an analog voltage, on the other. All told, the analog output voltage of the AMS 5812 is therefore ratiometric to the supply voltage.

The digital signal generated by the ADC and processed by the microcontroller, however, is not ratiometric to the supply voltage.

The additional D/A conversion necessary on the AMS 5812 also explains why the resolution of the digital signal on this OEM sensor is 14 bits, whereas that of the analog output signal is only 11 bits.

The following applies for the ratiometric signal from ratiometric condition (2) at  $V_{CC} = 5V$ :

$$V_{out,1}(P, V_{CC,1}) = V_{out}(P, V_{CC}) \cdot \frac{V_{CC,1}}{V_{CC}} = V_{out}(P, V_{CC}) \cdot \frac{V_{CC,1}}{5V} \quad (4a)$$

If, for instance, on the AMS 5812 a specific value of  $V_{OUT} = 0.5V$  is expected at a supply voltage of  $V_{CC} = 5V$  for zero pressure  $P_0$ , the following applies for  $V_{CC1} = 5V \pm 5\%$ :

$$V_{out,1}(P_0, V_{CC,1}) = 0,5V \cdot \frac{V_{CC,1}}{5V} = 0,5V \cdot \pm 1,05 = 0,5V \pm 0,025V \quad (4b)$$

This value is the correct output signal generated by  $V_{CC,1}$ .

This specifically means that the stability of the output signal is directly dependent on the stability of the supply voltage.



# AMS 5812 - Ratiometry in pressure sensors

## Ratiometric error

A ratiometric error is often stipulated on datasheets for ratiometric sensors. This describes the deviation of the measurement (output signal) from the value accrued in equation (4). Here, the following applies:

$$\frac{V_{out,1}(measured) - V_{out,1}(P, V_{CC,1})}{V_{out,1}(P, V_{CC,1})} \cdot 100\% = \text{ratiometric error} \quad (5)$$

The ratiometric error is not to be confused with the deviation of the output signal at  $V_{CC}$  with the output value at  $V_{CC,1}$ .

## Non-ratiometric pressure sensors

The demand for ratiometry stems from the behavior of sensing elements in the sensors used in the automotive industry. When the on-board 5 V supply voltage changes, engineers have to be certain that this is accounted for in the sensor's corresponding output value.

As many ratiometric sensors in vehicles are powered by a central voltage supply, they can all be uniformly corrected by the amount of fluctuation in voltage and thus synchronized. Furthermore, there is no need for an appropriate reference for each sensor – which is a not inconsiderable factor in modern vehicles with their multitude of sensors.

The typical output signal of a sensor with a 5 V supply, common in the automotive industry and also found on the AMS 5812, ranges from 0.5 to 4.5 V. Here, ratiometry means that the signal can change with the voltage supply of 5 V by  $\pm 5\%$  within the permissible range.

The advantage of this 0.5–4.5 V output signal, among other things, lies in its voltage levels. If the output signal measures  $< 0.3$  V or  $> 4.7$  V, for example, there is an error in sensor behavior which is thus detected electrically (the levels of 0.3 V and 4.7 V are accrued by calculating the permissible fluctuation in supply voltage of  $\pm 5\%$ ).



**Figure 4:** differential pressure transmitter AMS 4711

Sensors which permit a large supply voltage range (e.g.  $V_{CC} = 10\text{--}30$  V) or sensors which operate on supply voltages of  $> 6$  V have a stabilized 3 V or 5 V controller to power the internal electronic signal conditioning unit (CMOS IC). As there is no danger posed by a fluctuation in supply voltage here, the condition of ratiometry does not have to be taken into account.

This is how differential pressure transmitter AMS 4711 [4] from Figure 4 works, for example, with supply voltages which range from 8–36 V, thus satisfying industrial requirements. This sensor has an internal 5.5 V controller which powers the sensing element and ASIC. It can therefore generate a non-ratiometric output signal of 5 V.



# AMS 5812 - Ratiometry in pressure sensors

## Summary

Taking the example of the AMS 5812 OEM sensor, which has both an analog and a digital output, this article has endeavored to explain what is meant by the term “ratiometry”. It has shown why, on this sensor, the analog output signal is ratiometric yet the digital signal is not. The equation for ratiometric error has also been given – a factor which to date has been neglected in the analysis of errors.

A non-ratiometric pressure transmitter with an analog signal output is described in the example of the AMS 4711.

## Further information:

[1] AMS 5812 pressure sensor:

<https://www.amsys-sensor.com/products/pressure-sensor/ams5812-pressure-sensor-with-analog-and-digital-output/>

[2] Application note on Measuring over-and underpressure bidirectionally with one sensor:

<https://www.amsys-sensor.com/downloads/notes/ams5812-measuring-over-and-underpressure-bidirectionally-with-one-sensor-amsys-510e.pdf>

[3] Application note on digital and analog outputs:

<https://www.amsys-sensor.com/downloads/notes/ams5812-oem-pressure-sensor-with-analog-and-digital-output-amsys-511e.pdf>

[4] AMS 4711 pressure sensor:

<https://www.amsys-sensor.com/products/pressure-sensor/ams4711-analog-pressure-transmitter-5v-output/>

## Contact

AMSYS GmbH & Co. KG  
An der Fahrt 4  
55124 Mainz  
GERMANY

phone: +49 (0) 6131/469 875 0  
fax: +49 (0) 6131/469 875 66  
email: [info@amsys-sensor.com](mailto:info@amsys-sensor.com)  
internet: <https://www.amsys-sensor.com>